

## Application

AC-51 and AC-52 control dampers employ aluminum airfoil blades and a rugged hat channel frame to provide extremely low leakage and exceptional air control in medium to high pressure and velocity applications.

## Standard Construction

**Frame:** 5" x 1" (127 x 25) galvanized steel hat channel with interlocking corner gusset. Equivalent to 13 gauge (2.4) channel frame. Low profile head and sill are used on sizes less than 13" (330) high.

**Blades:** 6" (152) heavy gauge, dual wall extruded aluminum — airfoil. Parallel (AC-51) or opposed (AC-52) action.

**Axles:** 1/2" (13) diameter plated steel hex.

**Linkage:** Concealed in frame.

**Bearings:** Synthetic

**Seals:** PVC blade edge seals and flexible metal jamb seals.

**Control Shaft:** 1/2" x 6" (13 x 152) round drive axle with outboard shaft support bracket and bearing supplied on all single section dampers for field installation. Factory installed 3/4" (19) diameter jackshaft on all multiple section dampers.

**Minimum Size:** Model AC-51 (one blade): 5" x 5" (127 x 127)  
Model AC-51 and AC-52 (two blades): 5" x 10" (127 x 254)

**Maximum Size:** Single section: 60" x 72" (1524 x 1829)  
Multiple sections: Unlimited

## Options

- Factory installed actuators:
  - Manual locking quadrant (supplied loose)
  - 24 VAC  120 VAC  230 VAC
    - Pneumatic  Modulating
  - External mount (requires sleeve or sideplate option)
  - Internal mount (requires jackshaftering)
- Factory installed sleeve.  Factory installed side plate.
  - Gauge:  20 (1.0)  16 (1.6)
  - Length:  16" (406)  24" (610)  Other \_\_\_\_\_
- Transitions (sleeve required):  Flanged
  - Round  Oval
  - Duct connections:  DM-25  DM-35  S & Drive
- Flanged frame:  One side  Both sides
- PI-50 – Dual position indicator switch package.
- Actuator/Quadrant standoff bracket — accommodates up to 3" (76) thick insulated duct.
- Stainless steel oilite sleeve-type bearings.
- Extruded aluminum frame construction.
- Jackshaftering (required with internal mounted actuators and standard on all multiple section dampers).
- Vertical mounted blades with thrust washers.
- Face and by-pass assemblies:
  - Model MDFBR  Model MDFBH  Model MDFBV

## Ratings

Damper Width	Maximum System Pressure	Maximum System Velocity
12" (305)	10.0 in. wg (2.5 kPa)	6000 fpm (30.5 m/s)
24" (610)	8.4 in. wg (2.1 kPa)	5000 fpm (25.4 m/s)
36" (914)	6.1 in. wg (1.5 kPa)	4000 fpm (20.3 m/s)
48" (1219)	5.3 in. wg (1.3 kPa)	3000 fpm (15.2 m/s)
60" (1524)	3.1 in. wg (0.8 kPa)	3000 fpm (15.2 m/s)

**Leakage:** 7.0 cfm/ft<sup>2</sup> @ 10.0 in. wg (0.04m<sup>3</sup>/s/ m<sup>2</sup> @ 2.50 kPa)  
5.0 cfm/ft<sup>2</sup> @ 4.0 in. wg (0.03m<sup>3</sup>/s/ m<sup>2</sup> @ 1.00 kPa)  
3.0 cfm/ft<sup>2</sup> @ 1.0 in. wg (0.02m<sup>3</sup>/s/ m<sup>2</sup> @ 0.25 kPa)

**Temperature:** -25°F to 180°F (-32°C to +83°C)

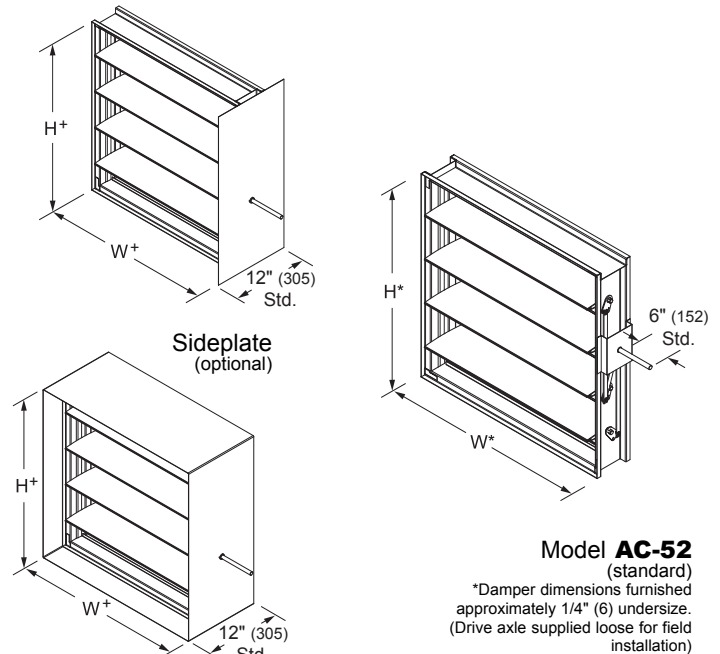

**Model AC-52**  
(standard)  
\*Damper dimensions furnished approximately 1/4" (6) undersize. (Drive axle supplied loose for field installation)

**Sleeve (optional)**  
\*Damper dimensions furnished approximately 1/4" (6) undersize (sleeve thickness not included).

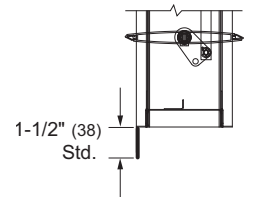

Flanged Frame

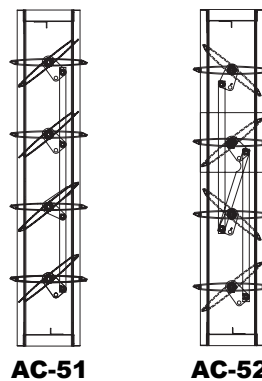

AC-51

AC-52

# Typical Damper Dimensional Details

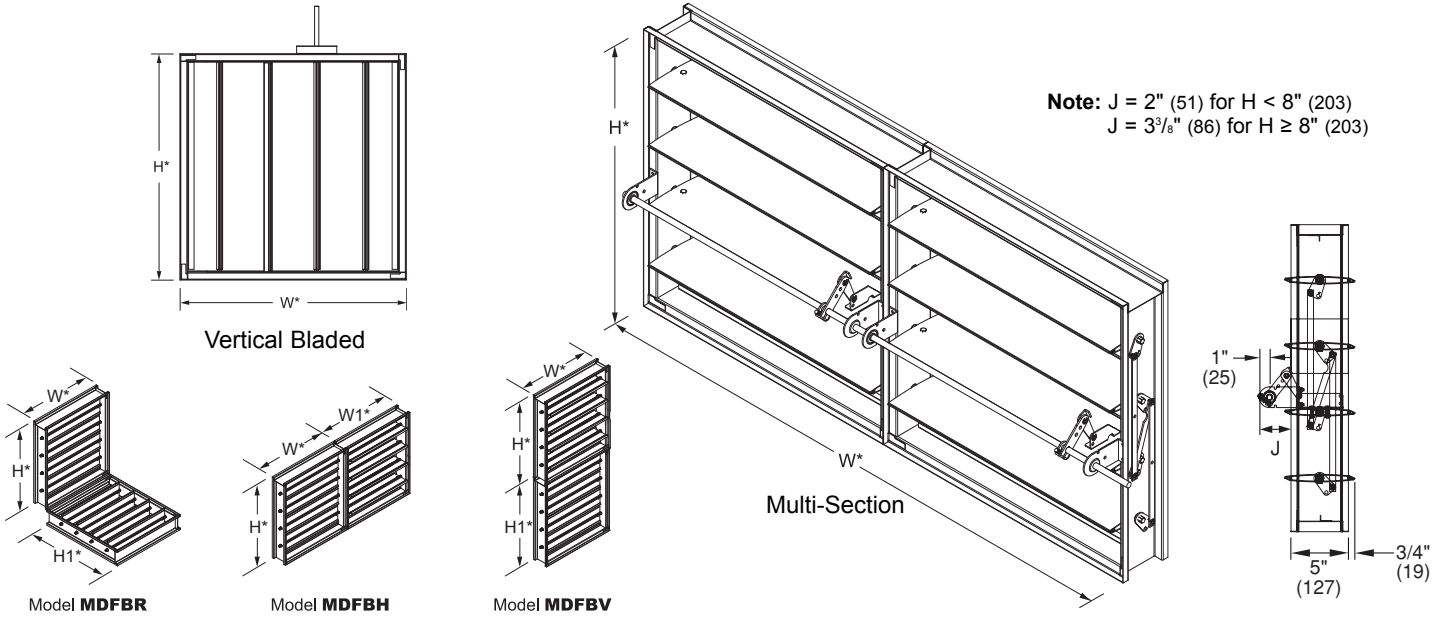

Dampers are designed to be self-supporting in the maximum single section size. When dampers are installed in multiple section assemblies, bracing may be required to support the weight of the dampers and to ensure structural integrity against system pressures. It is recommended that multiple sections be appropriately braced. In horizontal installations, it is recommended that suitable supports be installed every 8 feet of damper width. Dampers installed in vertical multiple assemblies and/or higher system pressures, may require additional bracing.

\*Damper dimensions furnished approximately 1/4" (6) undersize.

## Airflow Performance Data

### Pressure Loss vs. Velocity

Figure 5.3 — Ducted Inlet and Outlet

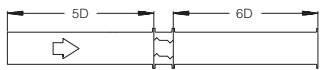
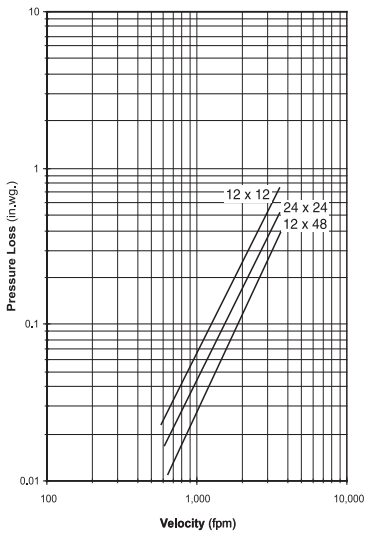

#### Ducted Inlet and Outlet

AMCA Figure 5.3 illustrates a fully ducted damper. This configuration represents the lowest pressure drop of the three test configurations because entrance and exit losses are minimized by straight duct runs upstream and downstream of the damper.

Figure 5.2 — Ducted Inlet

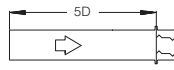
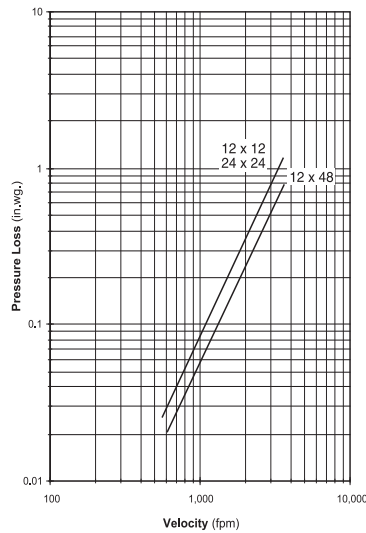

#### Ducted Inlet

AMCA Figure 5.2 illustrates a ducted damper exhausting air into an open area. This configuration has a lower pressure drop than Figure 5.5 because entrance losses are minimized by a straight duct run upstream of the damper.

Figure 5.5 Plenum Mount

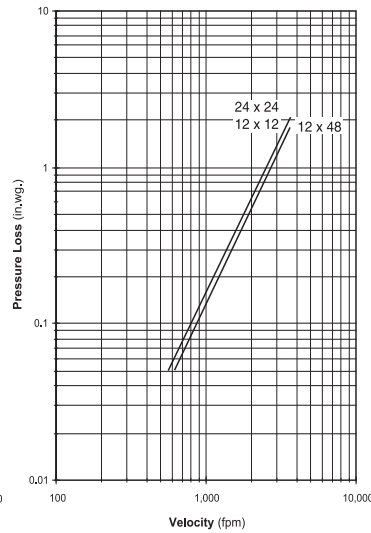

#### Plenum Mount

AMCA Figure 5.5 illustrates a plenum mounted damper. This configuration has the highest pressure drop because of extremely high entrance and exit losses due to the sudden changes of area in the system.

Pressure drop testing was performed in accordance with AMCA Standard 500-D using the three configurations shown. All data has been corrected to represent air density of 0.075 lb/ft. Actual pressure drop in any ducted HVAC system is a combination of many elements. This information, along with analysis of other system influences, should be used to estimate actual pressure losses for a damper installed in a given HVAC system.