

The following installation details apply to models **FD4D**, **FD4** and **FD2**

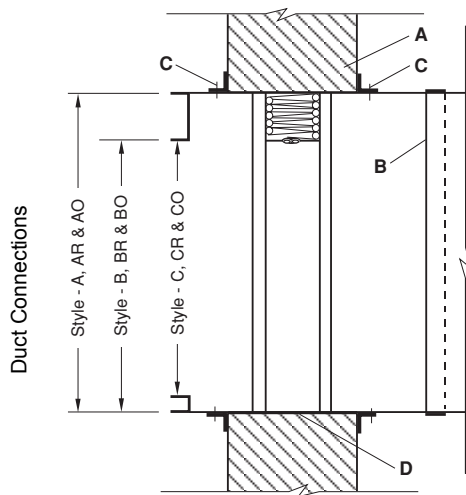

Damper Installation For Typical Fire Rated Partition

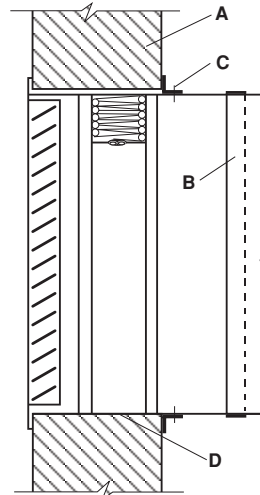

Damper Installation For Typical Flange Termination with Grille / Register

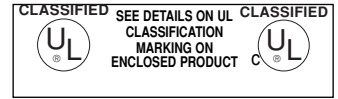

- A.** Concrete or masonry fire partition shown. See Wood Stud and/or Steel Stud Framing for Fire Dampers In Drywall and/or Cavity Shaftwall Partitions Supplemental Installation Instructions for further vertical installation details. The opening shall be a minimum of ¼" (6) with a maximum of ¾" (19) larger than the overall damper and sleeve assembly size. When openings are larger than ¾" (19), but less than 6" (152) the mounting angles must be a minimum of 16 gauge (1.5) and must be tall enough to overlap the opening by a minimum of 1" (25). Damper must be installed with leading edge of closed blade within the partition.
- B.** For rigid type duct connections, the sleeve shall be a minimum of 16 gauge (1.5) for dampers up to 36" wide by 24" high (914 × 610) and 14 gauge (1.9) for larger types. When lighter gauge sleeves are used, one or more of commonly used breakaway style connections are required. Refer to Sleeve Termination Supplemental Installation Instructions for further details. In no case will the sleeve gauge be less than the duct gauge to which it is connected. Damper sleeve shall not extend more than 6" (152) beyond the rated partition unless an access door or Smoke Detector is installed in the sleeve which then permits the extension to be a maximum of 16" (406).
- C.** Mounting angles shall be a minimum of ¾" × 1-½" tall × 20 gauge (19 × 38 × 1.0). For opening sizes ≤ 80" wide (2032), 96" high (2438), and not exceeding 26.67 square feet in area retaining angles are only required on one side of the partition and must be attached to the sleeve and the partition. For larger openings (or optional on smaller openings), 1-½" × 1-½" × 16 gauge (38 × 38 × 1.5). retaining angles are required on both sides of the partition and must be attached to the sleeve. Attachment to the sleeve shall be with No. 10 (M5) screws or bolts, ⅜" (4.8) diameter steel rivets, Quick-Lock joints or welds, at 12" (305) o.c. maximum. Attachment to partition/opening shall be with min. #10 fasteners with a minimum length as follows: For metal stud and the angles under the drywall, the fasteners must be a min. ½" long. For metal stud and the angles over the drywall the fastener must be a min. ½" longer than the thickness of the drywall. i.e. if the partition has one layer of ⅝" drywall on the attachment side, the screws must be ½" + ⅝" = 1-⅜" long. For wood stud openings, the min. length is 1-½" longer than the thickness of drywall on the attachment side. For concrete or masonry openings, the anchors must be for min. #10 fasteners- screws or bolts. In lieu of masonry anchors and bolts/screws, self-tapping masonry screws can be used. The fasteners in the partition should be located such that they are ½" below the top of the 1-½" flange of the retaining angles. Fasteners in the partition should be spaced 12" o.c. max. A minimum of two connections per side, top and bottom. A minimum ¾" × 20 gauge (19 × 1) flange termination may be used in lieu of mounting angles. Refer to Sleeve Termination Supplemental Installation Instructions and Framing for Fire Dampers for further details. Ensure that attachment device does not interfere with the operation of the damper and the free movement of the damper blades. Note: If optional sealing between the retaining angle (or flange) leg and the surface of the partition, wall, or floor, and/or between the retaining angle leg and the surface of the damper sleeve is required, the following sealants may be used: Dow-Corning 732 or GE RTV 108 or SCS 1201 RTV. These sealants should be applied such that they do not intrude into the annular space between the outside surface of the damper sleeve and the opening of the partition, wall, or floor, into which the damper/sleeve is being installed.
- D.** When joining multiple sections or fastening the damper to the sleeve, the damper shall be fastened with ⅜" (4.8) diameter steel rivets, Quick-Lock Joints, welds or No. 10 (M5) bolts or sheet metal screws at 8" (203) o.c. maximum. A minimum of two connections per side, top and bottom.

Note:

Annular space between damper sleeve and wall opening shall not be filled with firestop materials such as fill, void or cavity materials.

DUCT SIZES	Model FD4	Model FD4-SS	Model FD4D		Model FD4TL	
	GALVANIZED STEEL	STAINLESS STEEL	GALVANIZED STEEL	STAINLESS STEEL	GALVANIZED STEEL	STAINLESS STEEL
Maximum Single Section	48" × 48" (1219 × 1219)	40" × 40" (1016 × 1016)	36" × 48" (914 × 1219)	36" × 36" (914 × 914)	36" × 48" (914 × 1219)	N/A
Maximum Multiple Section	120" × 80" or 80" × 120" (3048 × 2032)(2032 × 3048)	80" × 40" or 40" × 80" (2032 × 1016)(1016 × 2032)	36" × 80" or 72" × 40" (914 × 2032)(1829 × 1016)	NA	36" × 72" or 72" × 36" (915 × 1829)(1829 × 915)	N/A
Minimum	4" × 4" (102 × 102)	4" × 4" (102 × 102)	6" × 6" (152 × 152)	6" × 6" (152 × 152)	4" × 4" (102 × 102)	N/A

Underwriter's Laboratories file #R14981. The product is also listed by CSFM File # 3225-1404:101

Information is subject to change without notice or obligation.

NOTE: Dimensions in parentheses () are millimeters.

The following installation details apply to models **FD4D** and **FD4**

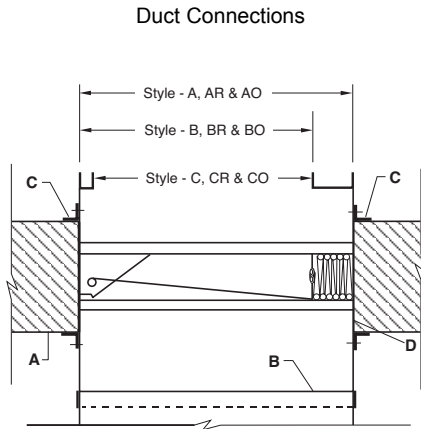

**Damper Installation
(2-sided Mounting Angle)**

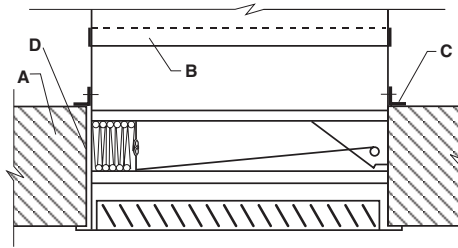

**Damper Installation For Typical
Flange Termination with Grille / Register**

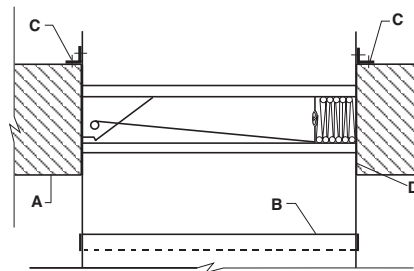
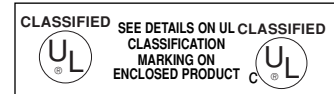

Single Side Mounting Angle Damper Installation

- A.** Concrete or masonry fire partition shown. The opening shall be a minimum or equal to ¼" (6) with a maximum of ¾" (19) larger than the overall damper and sleeve assembly size. When openings are larger than ¾" (19), but less than or equal to 6" (152) the mounting angles must be a minimum of 16 gauge (1.5) and must be wide enough to overlap the opening by a minimum of 1" (25). Damper must be installed with leading edge of closed blade within the partition.
- B.** For rigid type duct connections, the sleeve shall be a minimum of 16 gauge (1.5) for dampers up to 36" wide by 24" high (914 x 610) and a minimum of 14 gauge (1.9) for larger units. When lighter gauge sleeves are used, one or more of commonly used break away style connections are required. Refer to Sleeve Termination Supplemental Installation Instructions for further details. In no case will the sleeve gauge be less than the duct gauge to which it is connected. Damper sleeve shall not extend more than 6" (152) beyond the rated partition unless an access door or Smoke Detector is installed in the sleeve which then permits the extension to be a maximum of 16" (406).
- C.** Mounting angles shall be a minimum 1-½" x 1-½" x 16 gauge (38 x 38 x 1.5). Mounting angles are only required on the top side of the opening and must be attached to the sleeve at 6" (152) o.c. maximum, to the partition at 24" (610) o.c. maximum, with a minimum of two fasteners per side to both the sleeve and partition on all four sides. Alternately, mounting angles may be installed on both sides of the partition and must be attached only to the sleeve at 12" (305) o.c. maximum, with a minimum of two connections per side on all four sides. Attachment to the sleeve shall be a minimum of #10 (M5) steel fasteners: anchors, bolts, or self-tapping masonry screws. A minimum ¾" x 20 gauge (19 x 1) flange termination may be used in lieu of mounting angles. Ensure that the attachment device does not interfere with the operation of the damper and the free movement of the damper blades.

Note: If optional sealing between the mounting angle (or flange) leg and the surface of the partition, or floor, and/or between the mounting angle leg and the surface of the damper sleeve is required, the following sealants may be used: Dow-Corning 732 or GE RTV 108 or SCS 1201 RTV. These sealants should be applied such that they do not intrude into the annular space between the outside surface of the damper sleeve and the opening of the partition, or floor, into which the damper sleeve is being installed. Annular space between damper sleeve and opening shall not be filled with firestop materials such as fill, void, or cavity materials.

- D.** When joining multiple sections or fastening the damper to the sleeve, the damper shall be fastened with ¾" (4.8) diameter steel rivets, Quick-Lock Joints, welds, No. 10 (M5) bolts or sheet metal screws at 8" (203) o.c. maximum. A minimum of two connections per side, top and bottom.

DUCT SIZES	Model FD-10	FD-10D	Model FD-10
	GALVANIZED STEEL		STAINLESS STEEL
Maximum Single Section	40" x 40" (1016 x 1016)	36" x 36" (914 x 914)	40" x 40" (1016 x 1016)
Maximum Multiple Section	80" x 80" (2032 x 2032)	36" x 36" or 72" x 18" (914 x 914) (1829 x 457)	80" x 40" or 40" x 80" (2032 x 1016) (1016 x 2032)

Underwriter's Laboratories file #R14981. The product is also listed by CSFM File # 3225-1404:101.

* Individually sleeved dampers can be installed in partitions wider than the maximum U.L. multiple section size using the Support Mullion for Oversized Floor Openings. See Support Mullion for Oversized Floor Openings Installation Instructions for further details.