

Application

The NPR-BI pressure relief doors are designed to open inward to prevent damage to ductwork under excessive negative pressure. The NPR-BI mounts vertically and must be properly secured and sealed to the ductwork by welding or with high pressure sealing cement and screws or rivets.

Standard Construction

Frame: 12 gauge (2.8) galvanized steel.

Door Panel: 12 gauge (2.8) galvanized steel.

Hinge: Steel – continuous piano type.

Gasket: 1/4" thick (6.4) compressible sealed neoprene.

Latch: Factory set at desired pressure [3.0 in. wg to 8 in. wg (0.8 kPa to 2.0 kPa)] – fine-tune adjustable in field.

Springs: Coiled, automatically return door to closed position when pressure is relieved.

Available Sizes: 24" x 10" (610 x 152)
 24" x 12" (610 x 203)
 18" x 18" (457 x 356)
 24" x 24" (610 x 457)

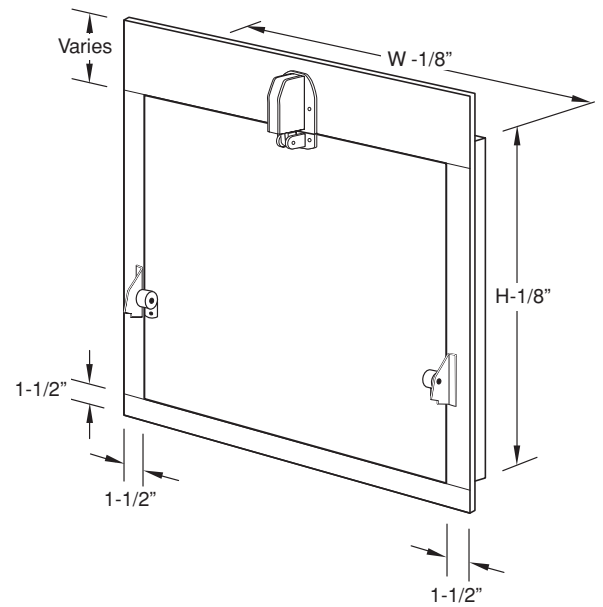

Model **NPR-BI**
 (standard)

Pressure Performance Data

Fan Curve

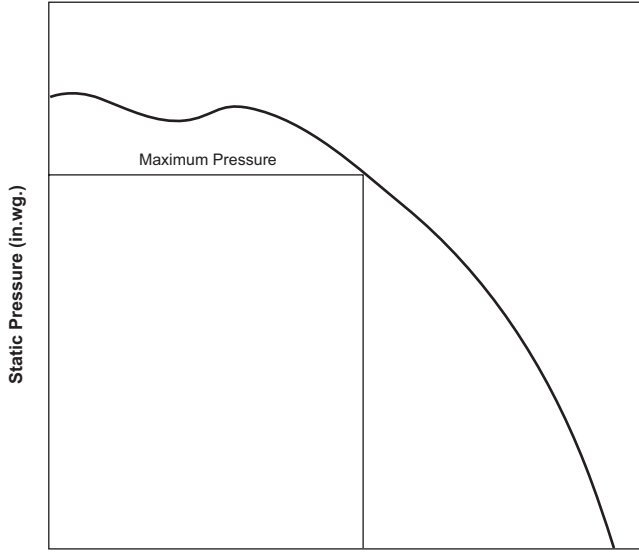

Flow Rate
Figure A

Relief Airflow vs. Static Pressure

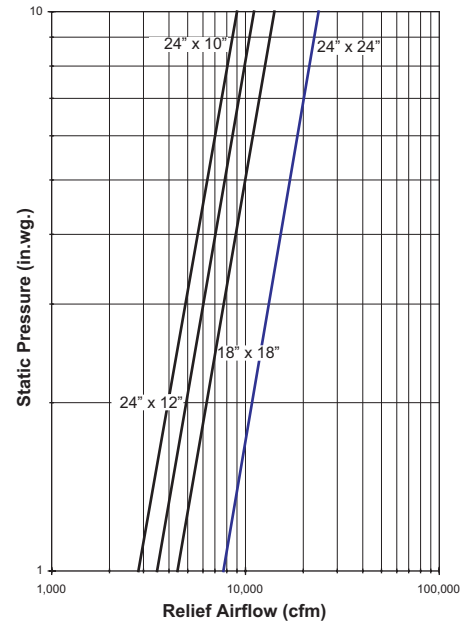

Figure B

Selection

1. Referencing the system fan curve, determine the maximum duct pressure allowed and read the system volume at this pressure (Figure A). This quantity (CFM) of air is the relief air required at this pressure. Alternately, if fan data is not available, use approximately 75 % of the total duct airflow volume.
2. For the relief air quantity found in step 1 and referring to Figure B, determine the relief air capacity of each door size at the maximum allowable duct pressure.
3. Select the appropriate quantity and size of doors that cumulatively total or exceed the relief air required.
4. Select the static pressure set point between 3" to 8". Reduce the relief pressure setting by approximately 20% for safety. The setpoint should be chosen near the maximum ductwork design pressure and at least 1" above the system's normal operating pressure. Pressure settings are factory set, but may be field adjusted.

Door Leakage Rate vs. Static Pressure

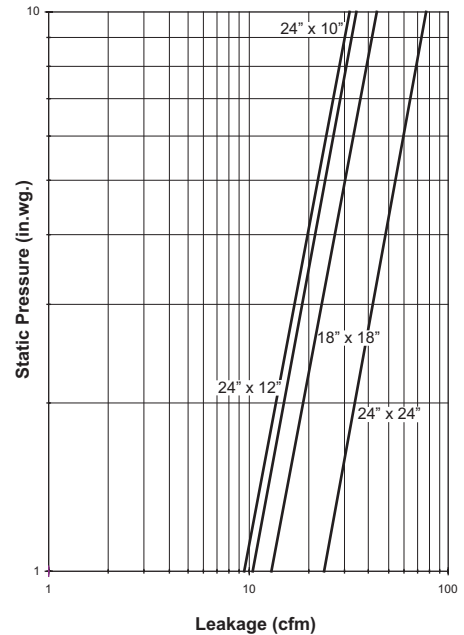

Figure C

Access Doors **NPR-BI** (1/1) June 2006